

April

ptl

20
20

Chair's
Annual
Report

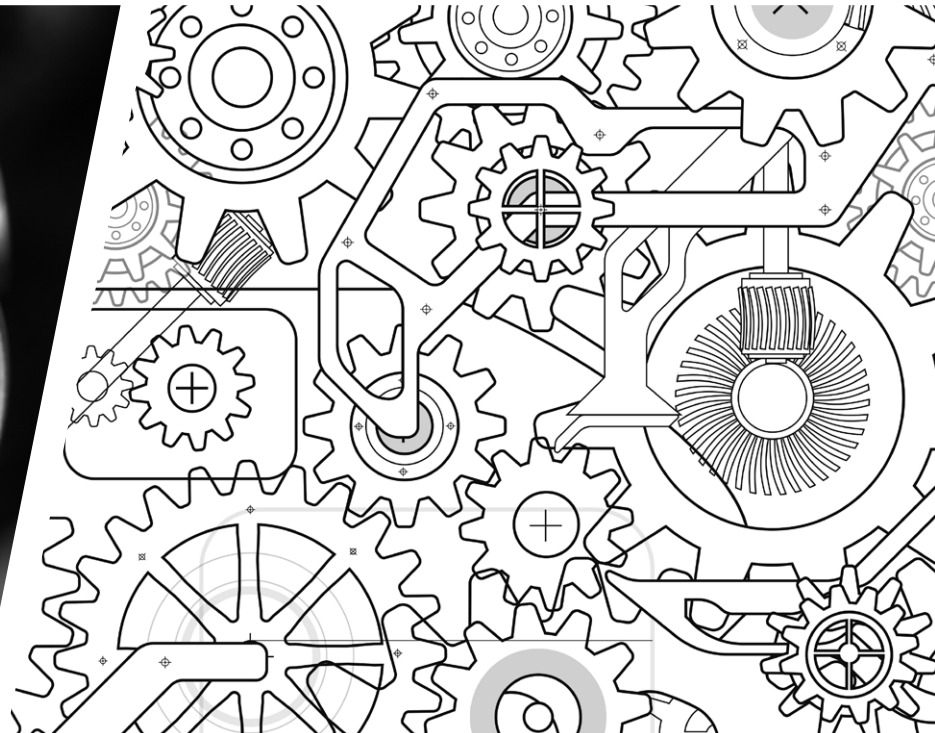

Utmost Life and Pensions
Workplace Personal
Pension Plans

The PTL Governance
Advisory Arrangement
(‘GAA’)

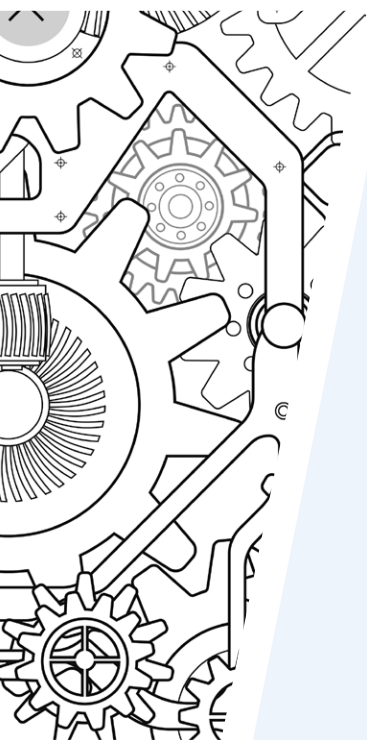

1

Introduction and Executive Summary

This report on the workplace personal pension plans provided by Utmost Life and Pensions (Utmost) has been prepared by the Chair of the PTL Governance Advisory Arrangement ('the GAA'). It is our fifth annual report covering these policies, which were previously provided by Equitable Life.

Utmost acquired these policies through a business transfer of Equitable Life to Utmost on 1 January 2020. This report covers a period where the policyholders were under Equitable Life and Utmost.

This report sets out our assessment of the value for money delivered to policyholders (see **Section 2**). It also explains the background and credentials of the GAA (see **Appendix 3**). The GAA works under Terms of Reference, agreed with Equitable Life, dated 9 November 2015. These are publicly available (see **Appendix 3**).

The workplace personal pension plans originally provided by Equitable Life were all Group Personal Pensions (GPPs). Policies have been divided into three groups, where different charges or with-profits guarantees applied. More details about the numbers of policyholders and their funds are shown in **Appendix 1**.













The GAA believes that deciding what represents 'value for money' is subjective and that value for money will mean different things to different people. We think value for money can be best judged by looking at the balance of all the costs paid by policyholders against the benefits and services provided from their policy, together with appropriate comparisons against other pension providers.

The GAA's opinion on the value for money delivered is that the GPPs offer reasonable to good value for money.

See **Section 2** and **Appendix 2** for more details of the value for money assessment.



A colour-coded summary of our value for money assessment is shown below:

Good ←      → Poor	Grouped Personal Pensions
Investments	
Communications and support	
Risk management: operational and financial	
Other factors: administration, options at retirement, etc.	
Overall benefit	
Level of charges	
Overall value for money assessment	

The GAA has not formally raised any concerns with Utmost / Equitable Life during the year but a number of challenges were raised (see **Section 3.3**).

Arrangements have been put in place to ensure that the views of the policyholders can be directly represented to the GAA (see **Section 3.4**).

Equitable Life announced its strategy in 2018:

- » To distribute all available assets in the with-profits fund fully and fairly to with-profits policyholders by increasing the current capital distribution to a level expected to be between 60% and 70%.
- » Converting with-profits policies to unit-linked policies and removing investment guarantees and with them any guaranteed annual increases.
- » Transferring all policies to Reliance Life (since renamed Utmost), where policyholders will see a continuity of service as, for the foreseeable future, their queries will be answered by the same staff.



The successful completion of the strategy was effective 1 January 2020. It was subject to member voting and court approval which both passed. Since 1 January 2020 responsibility has passed to Utmost. While the GAA has covered the key issues with Utmost since the business transfer the GAA has not had time to examine these thoroughly. We understand that most processes and personnel remain unchanged other than at the senior level and that the book remains a closed book in runoff. Therefore our Value for Money assessment is based on the period under Equitable Life and our current understanding of the Utmost position.

In this report the key issue is that with-profits guarantees have been removed in exchange for an uplift of at least 75% and policies converted to unit-linked.

If you are a policyholder and have any questions, require any further information or wish to make any representation to the GAA you should contact:

Utmost Life and Pensions

Walton Street
Aylesbury, HP21 7QW



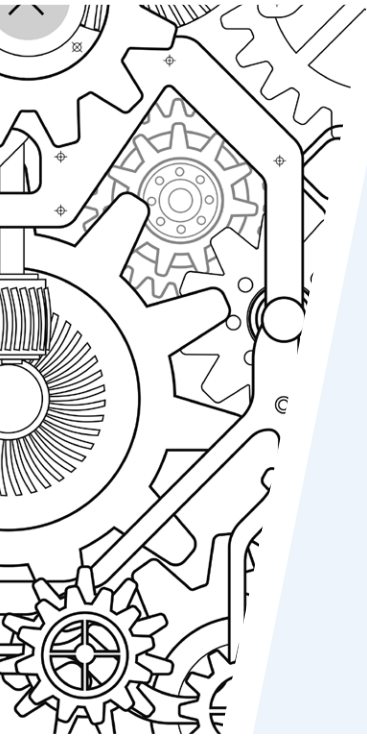

2

Value for money assessment

The GAA has assessed the value for money delivered by Utmost / Equitable Life to its workplace personal pension plan policyholders by looking at cost versus benefits. More detail about how we have done this is set out in **Appendix 2**.

Key highlights of our assessment

- » As Equitable Life was a closed mutual insurance society it had to distribute surplus capital fairly between all with-profits policyholders during the period of run-off. Our discussions with Equitable Life made clear that this was at the centre of all strategic decisions.
- » Equitable Life took great care in managing the distribution of reserves to achieve this aim of fairness between all with-profits policyholders. Ensuring a fair distribution was a foremost principle. The challenges of this led to the revised strategy in 2018 and business transfer in January 2020 as outlined in **Section 1**.
- » Equitable Life took steps to ascertain the views of policyholders through surveys of with-profits and unit-linked policyholders and feedback requests for retirees and for policyholders who transferred their benefits elsewhere.
- » Equitable Life also assessed the balance of fairness between with-profits and unit-linked policyholders and took steps to make unit-linked charges better reflect the underlying investment costs and to equalise charges between different series of policyholders.
- » Equitable Life removed the initial charges on contributions with effect from 30 June 2018.

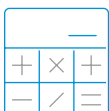

- » The fact that Equitable Life was not selling new products had allowed it to offer slightly more open guidance and communication to policyholders considering drawdown because it could easily demonstrate its independence and lack of conflict of interest compared to other providers.
- » The GAA found a strong culture of customer service within Equitable Life, which was commendable considering the firm was not taking on any new customers.
- » Policyholders have been required to transfer from Utmost if they wish to receive benefits by way of income drawdown, although partial withdrawals can be taken from policies and a drawdown product was launched in March 2020.
- » The closed book status in run-off has associated characteristics which may impact on policyholders in certain circumstances – for example a reduction in unit-linked fund values could have led to increased annual management charges. Equitable Life managed the issues of the run-off closely.
- » The investment review process was, once again, a key part of our discussions this year with Equitable Life. It will remain a key part in future years with the Utmost team.
- » The historical unit-linked contract terms require significant under-performance before the investment managers can be changed, although this does not prevent interaction and discussion of performance on an ongoing basis.
- » The investment instructions given to the investment managers in relation to with-profit funds were tightly defined and monitored. Equitable Life took action to gradually move its with-profits investments into cash prior to the move to Utmost but in such a way that it could be rolled back if the transfer to Utmost was not approved.
- » Equitable Life obtained transaction cost data from the relevant investment managers and this is now being published on Utmost's website. Transaction costs for the new fund range from JPMorgan Asset Management were not available in this period as the investments only started on 1 January 2020.
- » Utmost has a good understanding of the transaction costs and are good at distinguishing between asset management generated costs and Utmost generated costs and all are being measured accurately. The information can be found under the 'Fund Charges' section of the following linked page:

www.utmost.co.uk/investment-funds/fund-information-heritage-equitable-life-joining-utmost-1-january-2020/fund-information-heritage-equitable-life/



- » The GAA has reviewed the transaction costs and found them to be reasonable and insignificant compared to the overall charges, for example the fund transaction costs for the year to end September 2019 range from 0.35% for UK Equity to 0.007% for money market funds.
- » Equitable Life/Utmost addressed GDPR and their processes have been externally reviewed and signed off.

Overall the GAA's opinion on the value for money delivered is that the GPPs offer reasonable to good value for money.

The business transfer to Utmost crystallised an uplift of at least 75% for with-profits policyholders and improved the economies of scale for unit holders. At this stage we see no obvious disadvantage from the transaction as policyholders' views have been considered throughout the process. As the Utmost regime settles next year we will investigate this further.



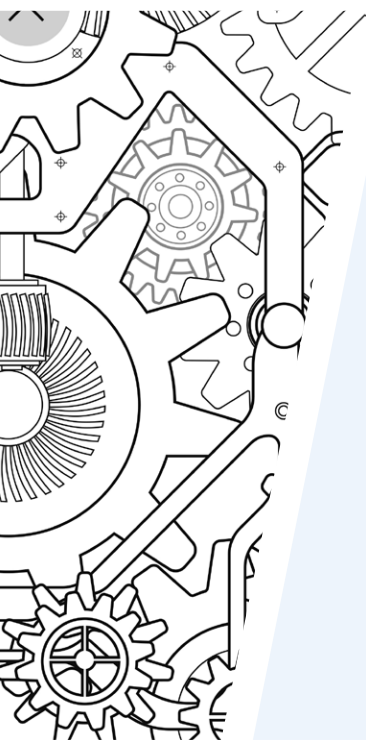

3

GAA activity and regulatory matters

This section describes the work that the GAA has done over the year and also covers the other matters which we are required to include in our annual report.

3.1 GAA actions this year

We prepared and issued a request for data on all the relevant workplace pension plan policies on 18 June 2019.

On 30 July 2019, members of the GAA visited Equitable Life to meet our main contacts and representatives from the investment and administration teams. This meeting provided updates on the proposed business transfer to Utmost, risk management, investment processes, transaction costs, GDPR and other specific considerations raised in the last year and an overview of administration. We had further follow up calls in November 2019 and January 2020.

Equitable Life and Utmost provided all the key information we requested.

The GAA held 4 meetings during 2019/20 to review and discuss the information we had received and to develop and improve the way that we assess value for money and report on this.

3.2 Independent Project Board (IPB)

The IPB issued a report into workplace pensions in December 2014 following a previous report from the Office of Fair Trading in 2013. The Financial Conduct Authority (FCA) required all pension providers who were subject to the IPB report to make proposals to governance committees (in this case the GAA) by 30 June 2015, and for the provider to agree a plan to address the risk of high charges of workplace pension savers in group pension arrangements. Equitable Life provided their proposals to the GAA in line with this timescale and proposals were agreed with the GAA for this purpose.

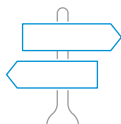

Equitable Life reviewed the pricing for unit-linked policies. This resulted in varying charges for expenses for different funds with effect from 1 April 2016. Charges now range from 0.5%pa to 1.0%pa. This applies to all series of policies, ending any difference between different series.

The GPPP2000 with-profits charges for expenses were reduced with effect from 1 April 2016 to 1.0%pa from 1.4%pa to bring these into line with the GPPP series policyholders.

3.3 **Concerns raised with Equitable Life / Utmost by the GAA and their response**

The GAA has not formally raised any concerns with Equitable Life or Utmost during the year covered by this report.

In the first year (2015), we challenged the lack of lifestyling facility for policyholders who wish to reduce risk in their investments in the run up to retirement, Equitable Life commented that this process is not necessarily applicable to with-profits policyholders, which we accepted. Equitable Life believe that, following the introduction of greater flexibilities for policyholders, many would opt to take their funds as cash and therefore lifestyling (into bonds or cash) was no longer appropriate for them.

The challenges we made in 2016 related to the investment oversight and review processes. We questioned and discussed the investment review process for unit-linked funds at length including the committee structure and the roles of committees in setting of benchmarks and investment review. We also questioned the investment managers terms of engagement. This interaction showed oversight is undertaken within certain restrictions in the terms of engagement.

In 2017, we again challenged the investment oversight and review process. This interaction reiterated that oversight is undertaken within certain restrictions in the terms of engagement. We also reviewed the cyber security policies and implementation. We worked with Equitable Life to solicit policyholders' views on Value for Money.

In 2018, we again challenged investment oversight and review. Further, we tested the security of members' data through a review of the GDPR process. We also challenged Equitable Life on their approach to protecting workplace pensions in the light of the possible Utmost, then known as Reliance Life, transaction.

In 2019/2020 we have challenged the team on investment oversight for both Equitable Life and Utmost. We have been in close contact with regard to the business transfer process and the conversion of the with-profits funds.

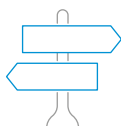

3.4 The arrangements put in place for policyholders' representation

The following arrangements have been put in place to ensure that the views of policyholders can be directly represented to the GAA:

- » The role of the GAA and the opportunity for policyholders to make representations direct to the GAA has been communicated via the Equitable Life and Utmost websites and has been included on annual benefit statements since April 2016.
- » Utmost will receive and filter all policyholder communications, to ensure that this channel is not being used for individual complaints and queries rather than more general representations which may be applicable to more than one policyholder or group of policyholders. Where Utmost determines that a communication from a policyholder is a representation to the GAA, it will be passed on in full and without editing or comment for the GAA to consider.

To date, no representations have been received via Equitable Life or Utmost nor direct to the GAA.

3.5 FCA extension of remit – PS19/30

The FCA has issued Policy Statement PS19/30, this details an extension of the remit of the GAA in two areas, which will apply from 6 April 2020.

The first is that the GAA will need to assess and report on Utmost's policies on Environmental, Social and Governance (ESG) issues for the pension policies and products that fall within our remit. This will include reporting on how they take account (if at all) of customer/policyholder/member views and concerns about ESG issues. It also extends to reporting on stewardship, which means looking at how the provider works with the asset managers to ensure that they are engaging with the underlying companies whose shares and bonds they hold, for instance to use voting rights and other mechanisms to influence the governance of those companies. The GAA will be looking at both the policies themselves and also how they are implemented in practice.

The second area involves 'investment pathways' for customers who go into income drawdown without taking financial advice. Utmost has confirmed that they are considering how they will provide investment pathways.

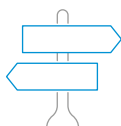

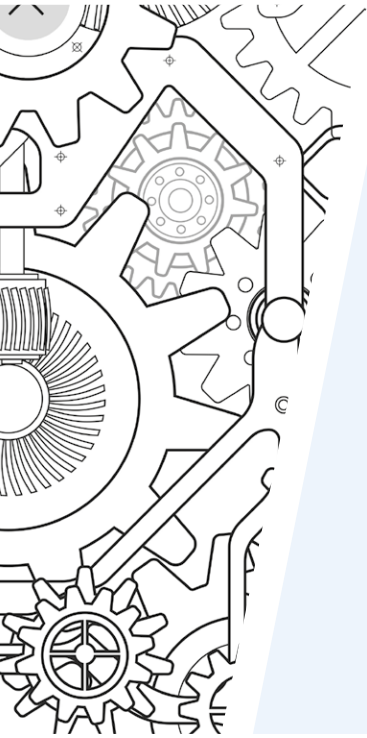

4

Next steps

This GAA report is for the year to 5 April 2020. The process of annual reports under the FCA requirements is ongoing and further annual reports will be required.

In the next year the GAA will:

- » Assess the level of transaction costs within the individual funds and consider how these are being assessed by Utmost.
- » Give in depth consideration to the investment review process.
- » Review Utmost's Enterprise Risk Management policy and internal controls in detail.
- » Continue to challenge Utmost to ensure that costs and charges for members are minimised and represent value for money.
- » Work with Utmost to understand how ESG issues are incorporated into the investment process.

If you are a policyholder this report is for your information only and you do not have to take any action.

If you do have any questions, require any further information or wish to make any representation to the GAA you should contact Utmost at the address shown on page 4.

Keith Lewis

Chair: PTL Governance Advisory Arrangement



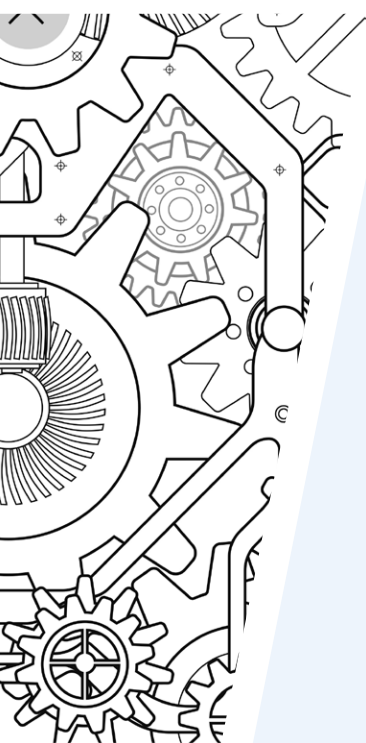

Appendix 1

Summary of workplace personal pension plan data at 31 May 2019

	GPPP 3.5% GIR With-profits fund available with 3.5%pa guaranteed investment return plus unit-linked	GPPP 0% GIR With-profits fund available with 0%pa guaranteed investment return plus unit-linked	GPPP2000 0% GIR With-profits fund available with 0%pa guaranteed investment return plus unit-linked
Number of employers Non-qualifying for auto-enrolment	989	1,383	54
Total number of policyholders Contributing	5,817 46	9,571 53	284 3
Non-contributing	5,771	9,518	281
Total value of assets (market value)	£160m	£120m	£2m

Notes

The data provided is at May 2019. Following completion of the business transfer to Utmost, the with-profits guarantees have been removed with effect from 1 January 2020.

These plans are not used for auto-enrolment.



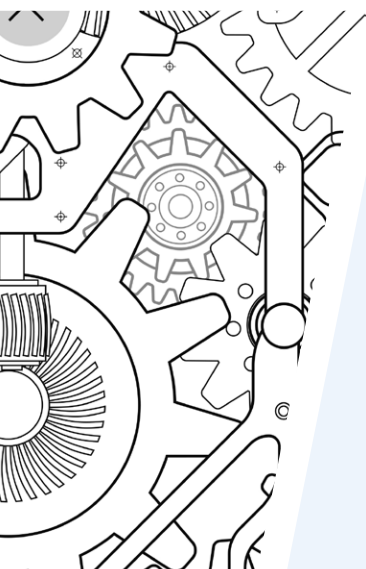

Appendix 2

Value for money assessment

The GAA believes that value for money is necessarily highly subjective and will mean different things to different people over time, depending on what they consider important at that time. What is clear is that it is always a balance of cost versus benefits. There is not enough publicly available data to perfectly assess value for money in an absolute or relative way. We have, however, been able to carry out limited relative comparison of the costs and benefits of these workplace personal pension plans with similar products from similar providers.

The GAA has assessed the value for money delivered by Equitable Life / Utmost to its workplace personal pension plan policyholders by looking at cost compared against our evaluation of the quality of the benefits.

We have looked at the benefits offered to policyholders in four main areas – investment, communications, risk management and administration, including other features such as the range of options available at retirement. In making our overall assessment of the quality of the benefits and standards achieved, where possible we have taken into account the likely needs and expectations of this group of policyholders, based on the information available to us.

We have looked at the total ongoing cost of the policy by analysing all the charges, which may be applied in a number of different ways.

Finally, we have considered the quality of benefits offered versus the charges deducted, to reach an overall opinion on value for money. Where possible, we have formed our opinion taking into account the benefits and charges of other similar providers.

In each area of benefits, in the tables on the next few pages we have described the features in the left hand column, based on the information given to us. Our opinion on quality is given alongside in the right hand column.

Where we have used technical pensions terms or jargon, these are explained in the glossary at the back of this report.



Description of arrangements

GAA assessment and opinion

Investment

Design and performance of investment strategies

The GPPs do not have a default investment fund or strategy, but a significant proportion of policyholders were invested in the with-profits fund, particularly in the group of policies where there was a guaranteed return of 3.5%pa.

There are no default investment options, and there have always been a limited number of lifestyling strategies. Equitable Life determined that adding a lifestyling option for unit-linked policyholders was not a good use of policyholders' money. In 2016, there was a review and rationalisation of funds and policyholder interests and views were considered, moving and changing funds where necessary. This process was not completely independent as the contracted investment manager was the key participant in that review.

Lifestyling has now been introduced under Utmost and while there is no default, this is not required as there is no new business which would require a default. All business is existing and therefore already invested.

Lifestyling was not available as an option until GPPP2000 series of policies which offered one lifestyling strategy based on switching to gilts and bonds over the 5 years prior to retirement. This was subsequently withdrawn.

The with-profits fund was managed by an external fund manager, BlackRock. The part of the with-profits funds matching the guaranteed liabilities concentrated on matching cashflows, with cash and liquid assets for the remaining monies. That equates to around £3.4 billion matched cash flows out of £4.4 billion. Cashflows over 7.5 years were matched with UK Government bonds with shorter term payments matched with corporate bonds.

With-profits closed as of 1 January 2020, these funds have been put into cash pending policyholders' decisions, if policyholders do not make a decision these will be invested into the new lifestyling strategy.

The Asset and Liability Committee defined the guidelines for BlackRock and reviews the unit-linked investment fund range. Utmost has an equivalent Committee.

There are no formal default funds reflecting that there was no requirement for or no expectation of these at the time policies commenced when Equitable Life was open to new business.

Most policyholders were invested in with-profits funds which were managed very well in significant detail, or in unit-linked funds with a broad sweep of asset classes.

The unit-linked funds are regularly reviewed through committee structures. The investment managers input directly into the Asset and Liability Committee and the Unit Pricing Committee which need to ensure they maintain the ability to scrutinise independently from the investment managers. We accept that the review process carries a risk of disproportionate cost for this number of policyholders.

For with-profits investment management, the liaison, instruction and review between Equitable's Asset and Liability Committee and BlackRock appeared very tight and well developed in detail.



Description of arrangements**GAA assessment and opinion****Fund range available**

The Equitable Life unit-linked fund range gave policyholders a choice of 11 funds, covering single asset classes and some multi-asset managed funds. External fund managers, Aberdeen Standard Investments (previously Aberdeen which merged with Standard Life in August 2017), were responsible for managing the funds. The range was reviewed in 2015 and significantly rationalised and simplified during 2016. Prior to review there had been over 100 funds (including some not available to workplace pension policyholders) which has now reduced to 11.

There is no impact of the Standard Life / Aberdeen Asset Management merger. The relationship predates the Aberdeen Asset Management purchase of Scottish Widows Investment Partnership.

Some policyholders were eligible to invest in the with-profits fund as one of the self-select options prior to 1 January 2020.

JPMorgan has been introduced as the new investment manager for self-select options and will be phased in within heritage Equitable Life funds.

JPMorgan Multi-asset funds and Lifestyle have been added to the range.

We believe that a good range of funds is available for policyholders who wish to select funds, representing the major asset classes including a with-profits option that was available until 1 January 2020. We believe the rationalisation and simplification was helpful to policyholders, and was implemented successfully.

With-profits policyholders with policies written before 1 July 1996 historically benefitted from a guaranteed investment return of 3.5%pa in the with-profits fund, which we believe represented a valuable benefit. Compensation for giving up this benefit was part of the uplift added to the policy values when they converted to unit-linked.

The lifestyling strategy was only available to a very small number of policyholders. It was reviewed and subsequently withdrawn because policyholders are no longer required to buy an annuity.

How investment performance of the fund range is reviewed and any changes made

The investment review process was a key part of discussions with Equitable Life. It will remain a key part in future years with Utmost. In overall terms these discussions improved the GAA's perspective of the process undertaken.

The GAA has been given a high level view of the Utmost investment process, but this will require further work in future years.

The performance of the with-profits fund and unit-linked funds were regularly reviewed by the Asset and Liability Committee, the Executive Committee and Board of Equitable Life, Utmost has equivalent structures. The terms of reference include reviewing investment performance figures against agreed investment objectives.

Most heritage unit-linked policyholders use the managed fund. This is managed by Aberdeen Standard Investments. The fund charges across the range of unit-linked funds vary from 0.5%pa to 1.0%pa.

The main committees monitoring investments were the Asset and Liability Committee (Equitable Life internal only)

Evidence has been provided that the characteristics and net performance of the investment strategies were regularly reviewed by the With-Profits and Asset and Liability Committees.

The rationalisation in 2016 to 12 funds (including with-profits) was beneficial from both a governance viewpoint and to facilitate a manageable policyholder choice.

As with all features, further future development of investment options would have had an associated cost which would have had to be borne by the mutual's with-profits policyholders and therefore incurring such costs was not necessarily in the policyholders' best interests.

The Committee structure to review unit-linked investment performance is substantial but the process has some



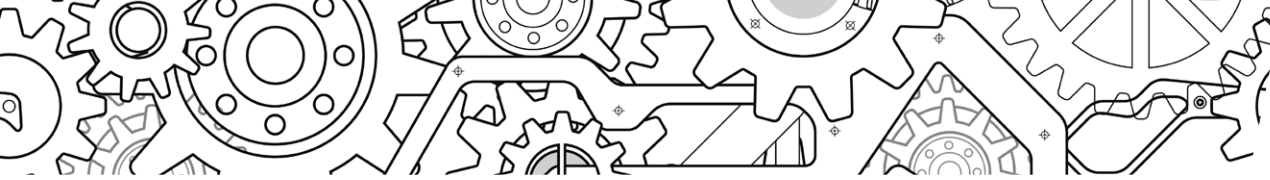

Description of arrangements

GAA assessment and opinion

How investment performance of the fund range is reviewed and any changes made (continued)

which met monthly; and the Joint investment Committee (Equitable Life and Aberdeen Standard Investments) which met bi-monthly. The agendas for these committees showed a wide-ranging remit.

For unit-linked funds there are triggers for further discussion and Equitable believed that having reviewed and overhauled the unit-linked funds recently there was a need for these to run for a period of time to allow for proper performance reviews. The historical unit-linked contract terms require significant under-performance before the investment managers can be changed, although this does not prevent interaction and discussion of performance on an ongoing basis. The terms mean Utmost do not, until 2022, have unfettered freedom to change unit-linked investment managers.

The Asset and Liability Committee's Terms of Reference include investment oversight as follows:

The overall objective of the Committee was to deliver the Society's stated strategy: "To recreate policyholder value by distributing all of the assets amongst With-Profits policyholders as fairly and as soon as possible". This has now been achieved as the with-profits fund is closed. Policyholders have been put into cash funds until they make choices as to their future investments or they will automatically move to a lifestyle option if they don't make a choice. Some may well withdraw or transfer their funds and there are revised investment options, including a lifestyle option, for those who choose to stay with Utmost.

limitations in the ability to make changes of investment manager if this became necessary. The rationalisation of the fund range was sensible and well-managed.

The Asset and Liability Committee undertake their Terms of Reference comprehensively.

The GAA will review the statistics around members' actions following the closure of the with-profits fund.

Transaction costs

Transaction costs for the with-profits fund were effectively absorbed by Equitable Life. With-profits investments shared in the profits and losses of the Society and the investment return passed on to policy values was a smoothed return at the discretion of the Society.

Equitable Life/Utmost have provided considerable information regarding transaction costs and this is available on the Utmost website. The information can be found under the 'Fund Charges' section of the following linked page: www.utmost.co.uk/investment-funds/fund-information-heritage-equitable-life-joining-utmost-1-january-2020/fund-information-heritage-equitable-life/

The GAA has reviewed the transaction costs and found them to be reasonable and insignificant compared to the overall charges, for example the fund transaction costs for the year to end September 2019 range from 0.35% for UK Equity to 0.007% for money market funds.

Utmost and Equitable Life have made efforts to provide information and details have been provided for each fund.

Utmost and Equitable Life have a good understanding of transaction costs and are good at distinguishing between asset management generated costs and costs generated by the company. All transaction costs are being measured accurately.

Within the constraints we have been able to conclude reasonable costs are close to what may be expected.



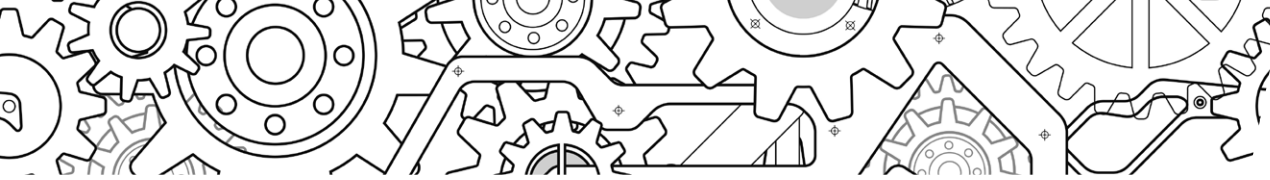

Description of arrangements

GAA assessment and opinion

Communications and Support

Statement of aims and objectives of investment strategies

The objectives of each unit-linked fund are stated and published on Utmost’s website.

Other than the closure of the with-profits fund there has been no significant change since the business transfer to Utmost.

The description of fund objectives and how investment management is undertaken has been revised on the website, it should be easier for policyholders to use the information in deciding whether to switch investment funds.

Overall quality of written communications, including education on pension saving

Sample policyholder communications have been provided including an annual benefit statement, pre-retirement wake up letter and the open market option provided at retirement.

Equitable Life have undertaken steps to ascertain views of policyholders through surveys of with-profits and unit-linked policyholders and feedback requests for retirees and for policyholders who transferred out.

Equitable Life liaised with the GAA on suitable survey questions for policyholders in 2017/8.

There has been no significant change since the business transfer to Utmost.

In our opinion, policyholder communications are of a high standard overall.

The steps taken to seek member views are extremely positive.

Other support, including telephone and online

General information is available on the website and policyholders can obtain details of their fund value and other support by telephone.

Equitable Life has used policyholder focus groups since 2014 to test reaction to some proposed changes to communications. During 2016/2017 four focus groups were employed to test communications with with-profits policyholders with alternative drafts provided to each group. The feedback was used to produce the final letter issued to these policyholders in January 2017 and to gauge what action policyholders would take on receipt of the letter. Focus groups continued throughout 2018 and 2019 to test policyholder views on proposed communications on the strategy.

Although policyholders cannot log onto the website to see their fund value, they can obtain this information over the phone during weekday working hours.

The addition of half-yearly statements in 2017 was a further additional benefit for members.

There has been no significant change since the business transfer to Utmost.

In our opinion, policyholder communications are of a high standard overall and policyholders have access to good telephone support. The customer support team appears well managed.

Our previous visit to Equitable Life encompassed meeting the telephone support teams. This showed particular commitment to a high quality service for policyholders including resourcing and re-allocation of resourcing to deal with varying work demands, together with a high level of management monitoring.

Some policyholders did request access to personal information online as part of the unit-linked policyholders focus group work, but Equitable Life considered that the cost of developing this could not be justified and the GAA supported this view.



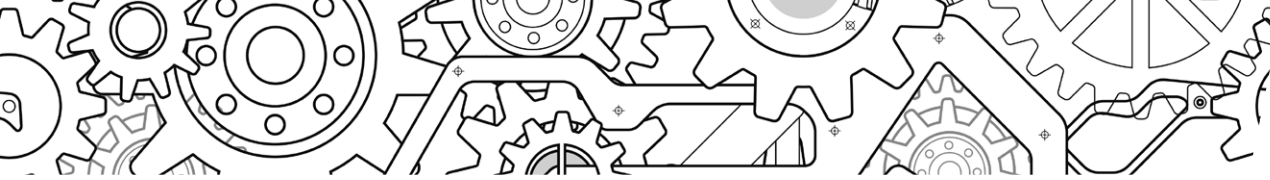

Description of arrangements

GAA assessment and opinion

When choosing retirement options

Wake-up letters are no longer issued at the 2 year or 3 week point before the selected retirement date. These were not regulatory requirements and were withdrawn in February 2018 so as not to encourage with-profits policyholders to take their benefits in view of the expected significant uplift to with-profits policy values on the completion of the Society's strategic plans.

The 'wake-up' pack is sent 4 months prior to retirement age.

Policyholders are pointed towards the Money Advice Service and Pension Wise service.

There has been no significant change since the business transfer to Utmost.

The retirement pack is concise, factual and generally helpful for policyholders.

The documents are of a reasonable quality, and good support is offered via telephone support.

It is understandable that investment in detailed projection and financial management internet tools by Utmost for policyholders may not be the best use of limited resources and have not been made available.

Risk Management

Security of IT systems and data protection

Significant security measures are in place and were discussed with the GAA on our site visit. Many of these incorporate staff procedures, requirements and training.

Cyber security is reviewed at quarterly meetings and testing of security levels. Outsourced IT suppliers are vetted after a comprehensive tendering process.

A GDPR implementation program was completed in 2018/19 and reviewed by an external legal firm. Equitable Life was content with the results.

There has been no significant change since the business transfer to Utmost.

We believe that IT security and GDPR compliance are adequate, based on the description of the frameworks given to us.

Note that we have not taken any independent advice from cyber security or data protection experts to support this opinion.

Financial strength and stability

The financial strength of Equitable Life was constantly considered as a central element of all decisions. While it did not have the depth of a large growing assurer, its financial position was carefully managed and issues of policyholder fairness were embedded in its structure – because some decisions which benefitted some policyholders may have been at the expense of other policyholders. As a result its resources were carefully managed.

There has been a significant change since the business transfer to Utmost, demutualisation and a closure of the with-profits book. The GAA has had sight of the Utmost Enterprise Risk Management Framework but have not had time to examine and walk through it in detail with Utmost.

The monitoring of the financial position was constant and detailed. This was reflected in variations to surrender terms over time and the overall risks and costs borne by Equitable Life. Equitable Life took all expected steps to manage this for policyholders.

The Utmost position is different in that the with-profits risks are now closed and only unit-linked risks remain. This is an action the GAA will pick up in the 2021 Report.



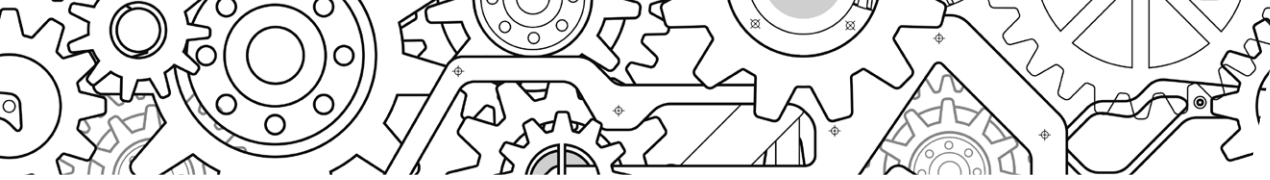

Description of arrangements

GAA assessment and opinion

Independent assurance of Firm controls

The internal audit function includes input external to Equitable Life. With the exception of external audit review of internal controls over financial reporting, there is no separate assurance audit accreditation for internal processes.

A detailed internal audit of risk management was undertaken in early 2016 and again in April 2018. This included:

- » Extent to which risk management arrangements support the achievement of strategic objectives.
- » Performance of risk oversight committee duties for a range of committees.
- » Strength of risk management within the Society's culture.

The Asset and Liability Committee was specifically included within the 2016 review.

The review concluded that the Risk Management Framework was generally functioning effectively and was embedded within the Society's Policies and processes. Also, that governance committees were adequately considering the Society's risks with risk actions being tracked through committees and frequently challenged and debated in committee meetings.

These Equitable Life processes have largely been inherited by Utmost.

Given Equitable's history and the centrality of fairness in its decision making and external scrutiny by policyholders, risk management was a key strength of Equitable Life.

Whilst no independent assurance of processes and procedures is carried out by an independent third party, we believe the internal audit process is appropriate and that actions are addressed where the audit identifies areas for improvement.

The GAA will review the Utmost internal controls in more detail in the 2021 reporting period.

Product development process to assist policyholder outcomes

There was a regular process of internal product review to ensure that products remained fit for purpose and suitable for policyholders.

These Equitable Life processes have largely been inherited by Utmost.

We believe that the process of internal product review is appropriate and that actions are addressed where the audit identifies areas for improvement.

The GAA will review the Utmost internal controls in more detail in the 2021 reporting period.

Processes for protecting policyholders against fraud and scams

Various processes were in place including multiple security checks before the provision of information and signature checking. Transfer requests were checked against registers of schemes and payments had a strict internal authorisation process.

These Equitable Life processes are largely inherited by Utmost.

Equitable Life took all expected reasonable checks against fraud and scams.

The GAA will review the Utmost internal controls in more detail in the 2021 reporting period.



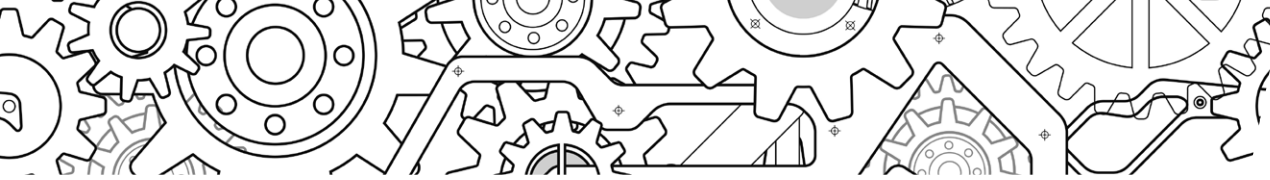

Description of arrangements

GAA assessment and opinion

Administration service and core financial transactions

Administration is carried out in house and evidence has been provided of performance against service standards of 5 and 10 working days.

If the agreed Service Standards are met, core financial transactions will be processed promptly and accurately.

Equitable Life provided details of complaints to us in regard of GPPs plus the outcome of the complaints. For the last 12 to 18 months these have run at the level of around 10 per annum of varying nature which is very low in relation to the number of policyholders.

We believe the administration service provided to policyholders is of a good standard and that core financial transactions are processed promptly and accurately.

Complaints are rare reflecting good service standards and are dealt with appropriately.

The administration team we met showed that high standards of administration are maintained with strong management from administration team leaders.

Other governance or support arrangements

Additional governance structures for the benefit of policyholders that were specific to Equitable Life included the With-Profits Committee for policyholders invested in the with-profits fund, as well as the considerable external scrutiny of some aspects of the running of Equitable Life by Parliament amongst others.

There were very clear communications with with-profits policyholders regarding capital distributions when circumstances required. This was not straightforward to manage but clear points were made within the communications.

These issues are now closed with the closure of the with-profits book.

There were no additional benefits to policyholders by virtue of their membership, and we noted that this was unlikely to be appropriate bearing in mind that as a mutual the Society's only source of funds was the with-profits fund.

With-profits policyholders benefitted from the additional governance provided by the with-profits committee. We have also noted positively the considerable external scrutiny of Equitable Life and the regular reviews of charges for expenses and guarantees.

We will review these issues once we review the statistics on the closure of the With-Profits book to ensure that this has all completed satisfactorily.



Description of arrangements

GAA assessment and opinion

Retirement options

At retirement, policyholders can take their whole benefits as cash or withdraw a series of Uncrystallised Funds Pension Lump Sums (UFPLS). If policyholders want to select income drawdown they have needed to transfer out of Equitable Life/ Utmost. Partial UFPLSs are allowed subject to a minimum residual fund value of £1,000. A minimum £1,000 partial UFPLS amount applies.

Alternatively, as well as the open market annuity option, they can choose to transfer to another provider for flexi-access drawdown or take advantage of the preferential annuity terms under an agreement with Canada Life.

Utmost launched an income drawdown product in March 2020.

The range of choice at retirement is reasonable for policyholders without encompassing all flexible options. Although a transfer to another provider has been required for flexi-access drawdown, no penalty or charge has applied on retirement at or after age 55 (or age 60 for protected rights benefits) and any guaranteed benefits were paid out in full prior to 1 Jan 2020.

The GAA will review the revised retirement options in 2021.

Charges and direct and indirect costs borne by policyholders

The Annual Management Charge (AMC) was 1.0%pa for with-profits. An additional annual charge of 0.5% was made for the with-profits fund to cover the costs of the guarantees. A reduced allocation rate of 95.5% where new contributions are being paid was removed with effect from 30 June 2018.

The with-profits charge was subject to regular formal review comparing charges against expenses in the past and projected in the future run-off, taking into account changes to unit-linked charges.

Following the recapture of the unit-linked business from Lloyds Banking Group in 2015, Equitable Life decided to review the pricing for unit-linked policies, because these were being subsidised by with-profits policyholders. This resulted in varying charges for different funds with effect from 1 April 2016. Charges range from 0.5%pa to 1.0%pa. This applied to all series of policies. A bid/offer spread of 4.5% applied to the small number of cases where unit-linked premiums are being paid but this has now been removed, apart from the GPPP2000 contracts where no such bid/offer spread exists.

Unit-linked investments are held in externally managed Open Ended Investment Company funds. Equitable Life met in full the Ongoing Charges Figures for each fund, with the exception of the Property Fund where those costs related to managing the property investments were borne additionally by the policyholders.

The AMC for with-profits of 1.0% (plus 0.5%pa for the cost of guarantees) represents a level of charge that is around average amongst providers who were part of the IPB review, based on the GAA's experience.

The appropriate charge is considered carefully by the Equitable Board.

Equitable Life have reviewed charges for unit-linked funds to ensure fairness between all policyholders and the new charges were introduced from 1 April 2016.

The removal of initial charges on contributions, whilst welcomed, has minimal impact as relatively few policyholders are paying contributions.

The GAA has reviewed the revised charges under Utmost and found them to be reasonable.



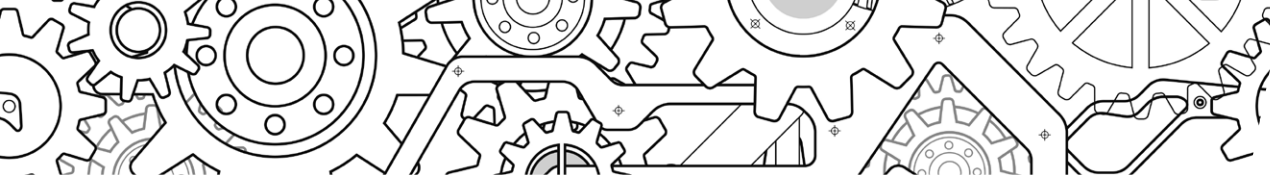

Description of arrangements

GAA assessment and opinion

Charges and direct and indirect costs borne by policyholders
(continued)

This is known as the Property Expense Ratio. The Property Expense Ratio for the year to 31 December 2018 was 0.44% pa.

Equitable Life removed the initial charges on contributions with effect from 30 June 2018.

All new JPMorgan Funds available to legacy With-Profits policyholders are charged at 0.75%pa with the exception of 'Cash and secure' funds at 0.50%pa and Property at 1%pa



Overall assessment of value for money

In our opinion the GPPs represent reasonable to good value for money, taking into account the benefits offered to policyholders.



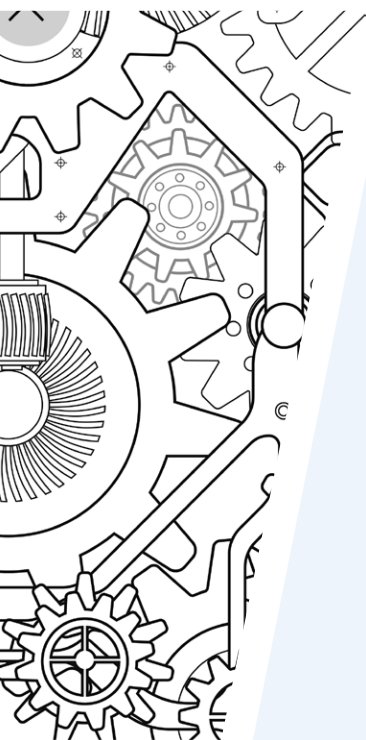

Appendix 3

Background and credentials of the PTL Governance Advisory Arrangement

In February 2015, the FCA set out new rules for providers operating workplace personal pension plans (called relevant schemes) to take effect from 6 April 2015. From that date, Providers had to have set up an Independent Governance Committee or appointed a Governance Advisory Arrangement whose principal functions would be to:

- » Act solely in the interests of the relevant policyholders of those pension plans; and to
- » Assess the 'value for money' delivered by the pension plans to those relevant policyholders.

The FCA rules also require that the Chair of each Independent Governance Committee and Governance Advisory Arrangement produce an annual report setting out a number of prescribed matters.

The PTL Governance Advisory Arrangement was established on 6 April 2015 and has been appointed by a number of workplace personal pension Providers. PTL is a specialist provider of independent governance services primarily to UK pension arrangements. Amongst other appointments we act as an independent trustee on several hundred trust based pension schemes and we sit on a number of IGCs. We have oversight or responsibility for in excess of £120bn of pension assets. More information on PTL can be found at www.ptluk.com.



All of PTL's Client Directors have been appointed to the GAA. More information on each of them, their experience and qualifications can be found at www.ptluk.com/Our-Team

Dean Wetton is also a member of the GAA. Dean is independent of PTL. Information on his experience and qualifications can be found at www.deanwettonadvisory.com

PTL, its Client Directors and Dean Wetton are independent of all of the providers participating in the GAA in so far as:

- » They are not directors, managers, partners or employees of any of the providers, or any company within their groups, or paid by them for any role other than as members of the GAA, nor are they members of the share option or performance related pay schemes of any of the providers nor have they been within the last five years.
- » They do not have a material business relationship of any description with any of the providers, or any company within their groups, and have not done so within the last three years.

Any potential conflicts of interest are recorded in a log and considered by the GAA in accordance with its conflict of interest policy.

The members of the GAA are appointed by the board of PTL. The board is satisfied that individually and collectively the members of the GAA has sufficient expertise, experience and independence to act in the interests of the members of the providers' pension plans.

The terms of reference agreed with Equitable Life can be found at:
www.utmost.co.uk/documents/160/gaa-tor-side-letter.pdf



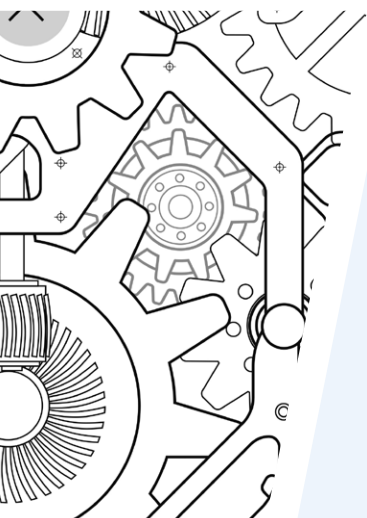

Glossary

Allocation rate

The proportion of the investment that is invested. Any deduction is typically to cover set up costs. Where the allocation rate is more than 100%, this is typically to reduce the effect of other charges or costs.

Annual Management Charge or AMC

A deduction made by the pension provider or investment manager from invested assets, normally as a percentage of the assets. The AMC is generally how the pension provider or investment manager is paid for their services.

Annuity

A series of payments, which may be subject to increases, made at stated intervals, usually for life. If the annuity is 'joint life', it will continue to a spouse (usually at a lower rate) after the death of the original person receiving the payments ('the annuitant').

Core financial transactions

The essential processes of putting money into a pension policy or taking it out, namely:

- » Investment of contributions.
- » Implementation of re-direction of future contributions to a different fund.
- » Investment switches for existing funds, including life-styling processes.
- » Settlement of benefits – whether arising from transfer out, death or retirement.

Default investment strategy

The investment funds into which contributions are invested for policyholders who do not select other specific investment funds from the full range of funds available.



Environmental, Social and Governance (ESG)

These are the three main factors looked at when assessing the sustainability (including the impact of climate change) and ethical impact of a company or business. ESG factors are expected to influence the future financial performance of the company and therefore have an impact on the expected risk and return of the pension fund investment in that company.

Flexible drawdown or Flexi Access Drawdown

An option for an individual to receive payments from their pension fund as they choose.

GDPR

The General Data Protection Regulations (EU) 2016/679 which is a regulation in EU law on data protection and privacy in the European Union and the European Economic Area.

Investment Pathways

Investment options designed to cater for the four FCA specified drawdown scenarios for non-advised policyholders intending to use their drawdown 'pot', either on entering drawdown or transferring-in assets already in drawdown.

Lifestyling

An automated process of switching investment strategy as a policyholder approaches retirement, in a way that is designed to reduce the risk of a policyholder's retirement income falling.

Transaction costs

A combination of explicit and implicit costs included within the price at which a transaction (i.e. buying or selling an asset) takes place.

Uncrystallised Funds Pension Lump Sum (UFPLS)

A method of drawing cash from a pension pot without buying an annuity or using drawdown.

With-profits

An insurance contract that participates in the profits of an insurance company. The insurance company aims to distribute part of its profits to with-profits policyholders in the form of bonuses.

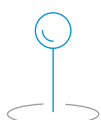

ptl

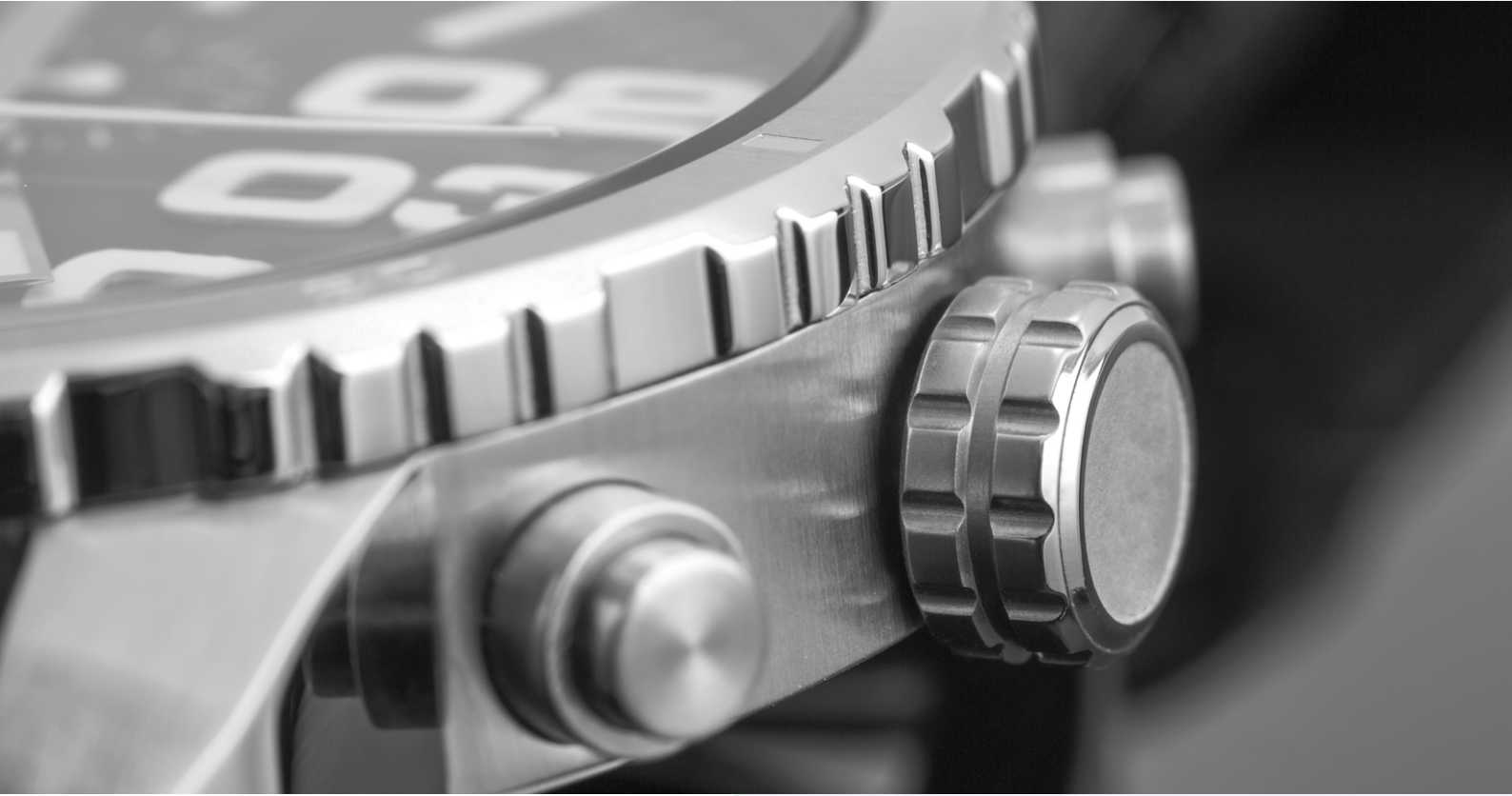

Personal
Pragmatic
Professional



Contact

info@ptluk.com
0303 366 0100

ptluk.com

Reading · London · Leeds · Birmingham